



US005249237A

United States Patent [19]

[11] Patent Number: **5,249,237**

Paddock

[45] Date of Patent: **Sep. 28, 1993**

[54] **AUDIO TRANSDUCER IMPROVEMENTS**

4,903,308 2/1990 Paddock et al. 381/202

[75] Inventor: **Paul W. Paddock**, McMinnville, Oreg.

FOREIGN PATENT DOCUMENTS

[73] Assignee: **Linæum Corporation**, Portland, Oreg.

1123506 5/1982 Canada .

8903160 4/1989 World Int. Prop. O. 381/197

[21] Appl. No.: **708,924**

Primary Examiner—Jin F. Ng
Assistant Examiner—Huyen D. Le
Attorney, Agent, or Firm—Klarquist, Sparkman, Campbell, Leigh & Whinston

[22] Filed: **May 31, 1991**

[51] Int. Cl.⁵ **H04R 25/00**

[52] U.S. Cl. **381/202; 381/194; 381/199**

[58] Field of Search 381/202, 204, 194, 195, 381/199, 89, 197

[57] ABSTRACT

An audio transducer having a pair of magnets supported to provide a magnet gap within which a flexible diaphragm supporting an electrical coil is received. The diaphragm is formed of a pair of flexible cylindrical webs joined at their centers to support the coil within the magnet gap. The diaphragm is provided with a row of perforations on either side of the gap to provide flexibility and is aligned centrally within the gap by tab portions partially cut from the diaphragm and folded to be adhered to the magnets.

[56] References Cited

U.S. PATENT DOCUMENTS

3,686,446	8/1972	Manger	179/115.5
3,978,353	8/1976	Kinoshita	310/8.1
4,327,257	4/1982	Schwartz	179/115.5
4,472,605	9/1984	Klein	179/115.5
4,584,439	4/1986	Paddock	179/115.5
4,590,333	5/1986	Strohbeen	179/115.5
4,897,877	1/1990	Tetzlaff	381/24

19 Claims, 6 Drawing Sheets

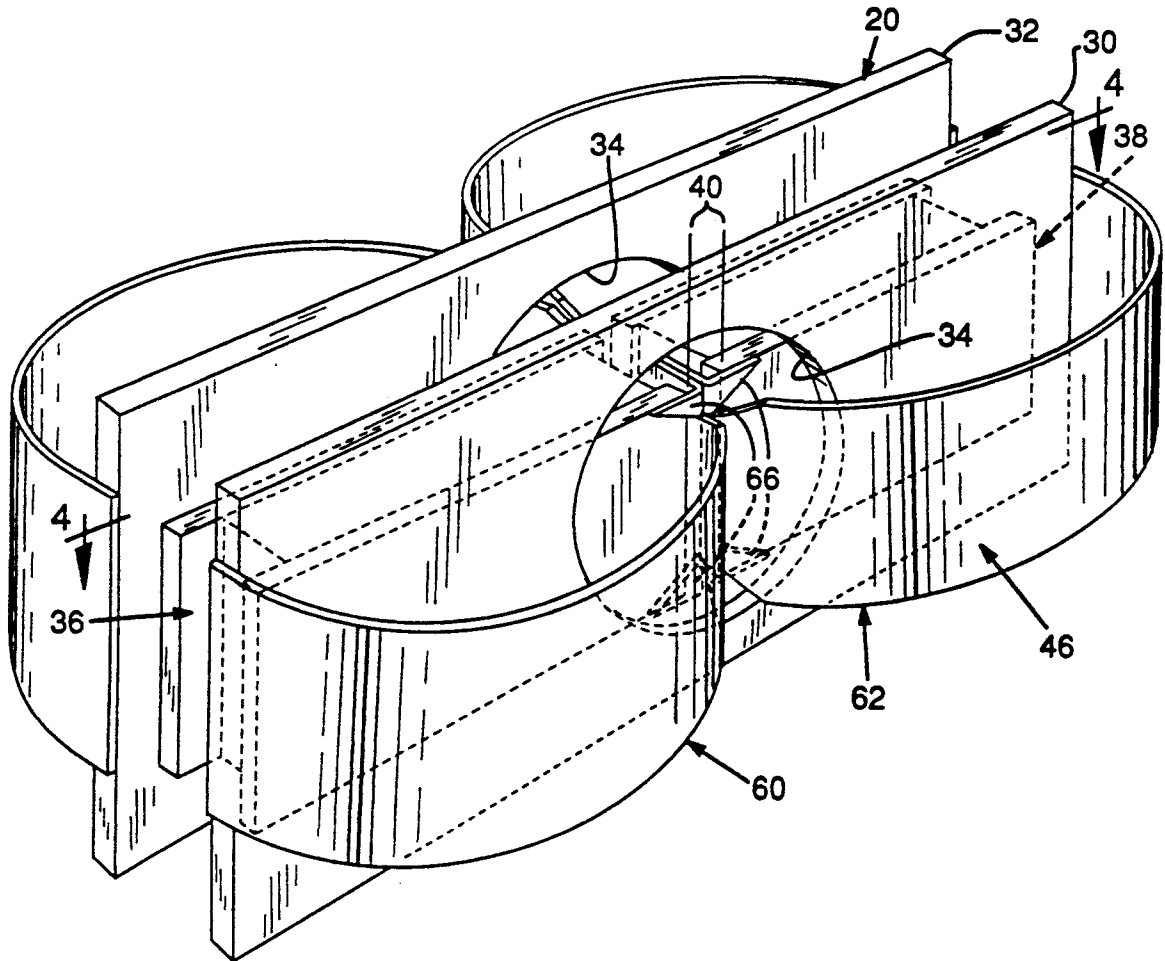

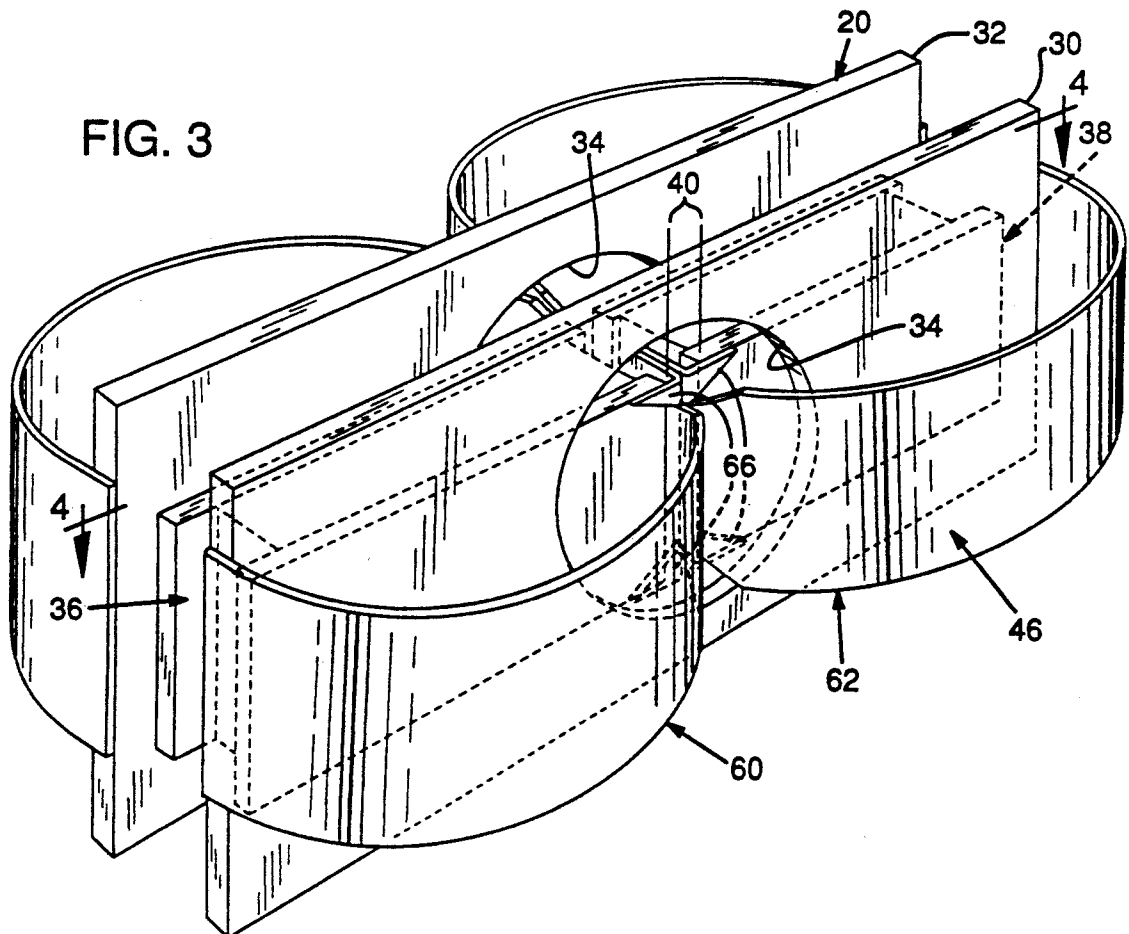
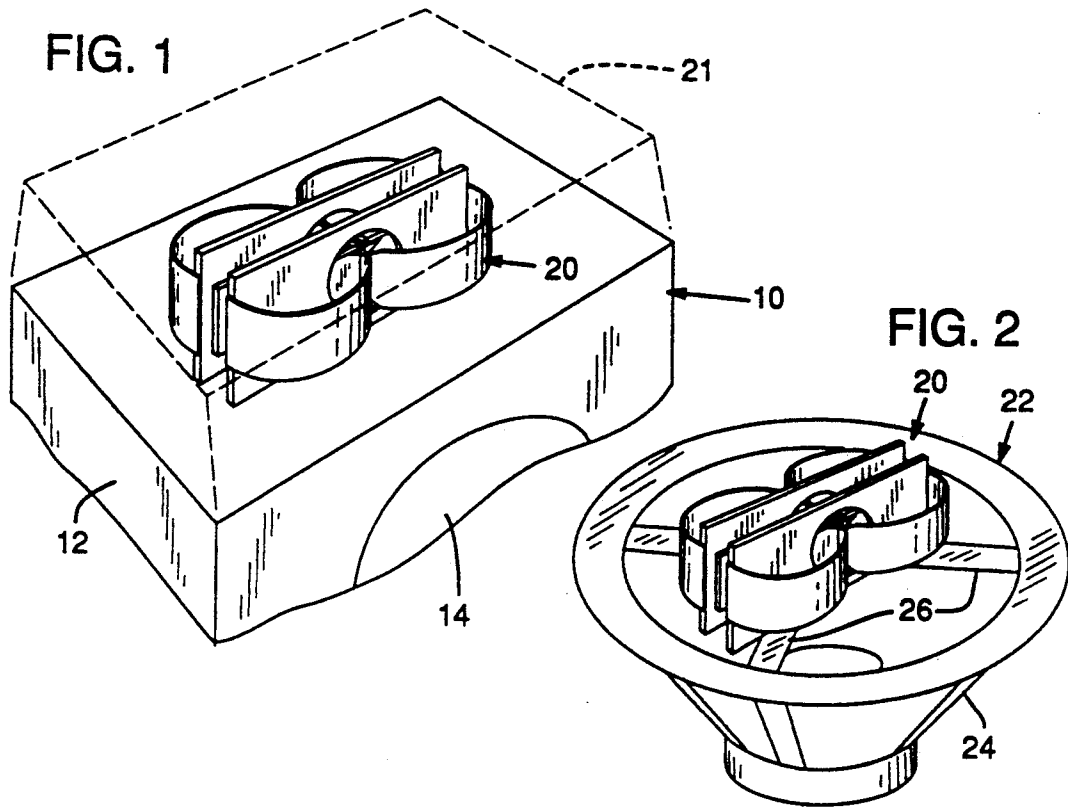

FIG. 4

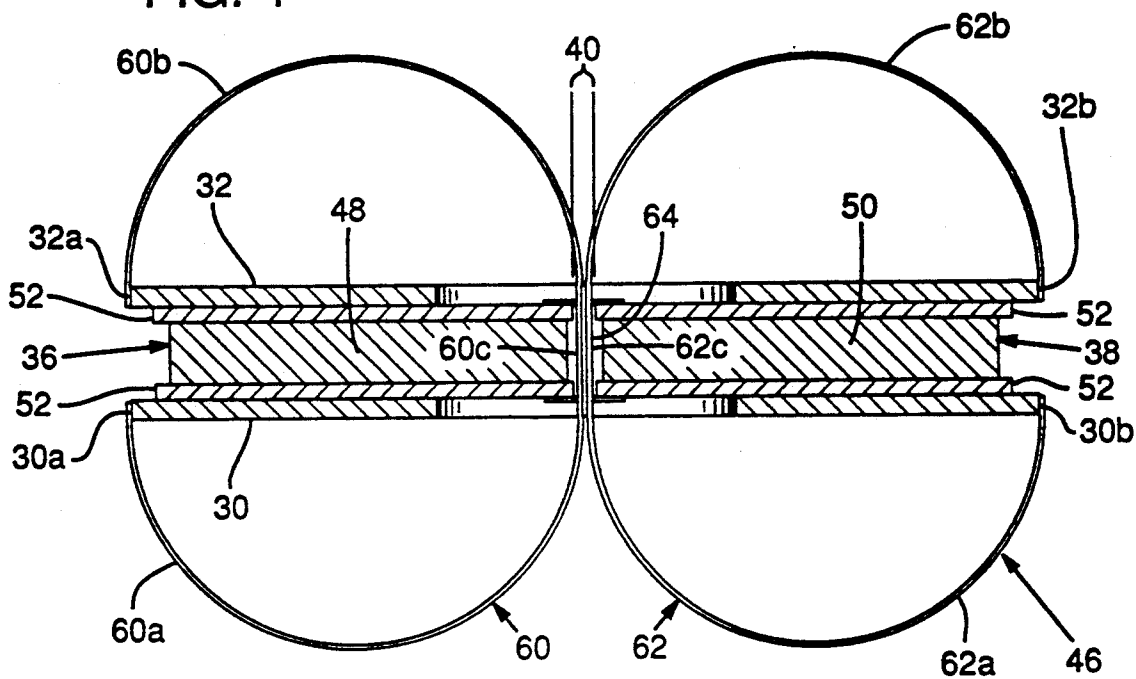

FIG. 5

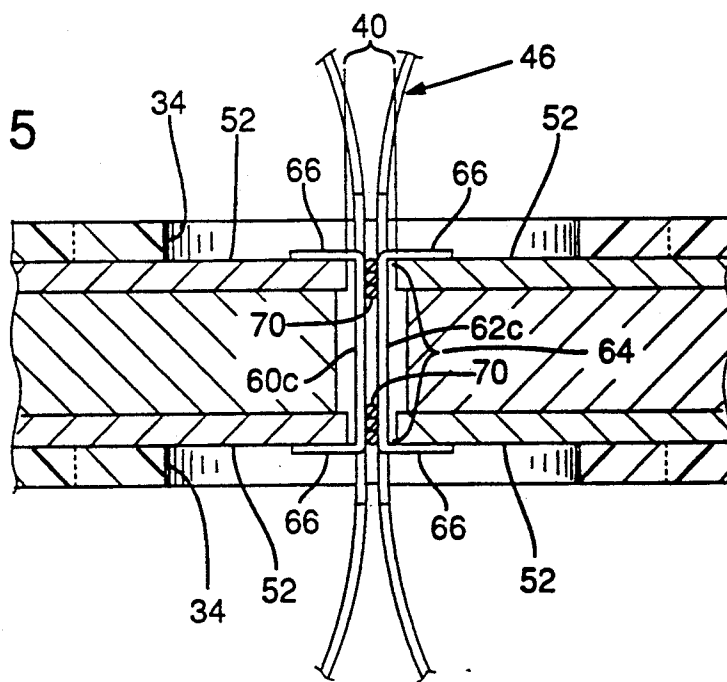

FIG. 6

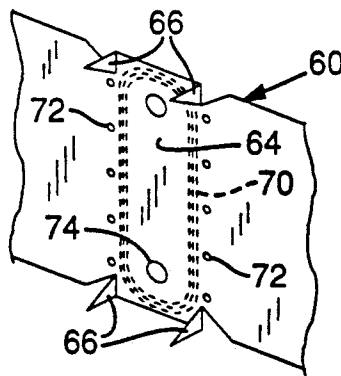

FIG. 14

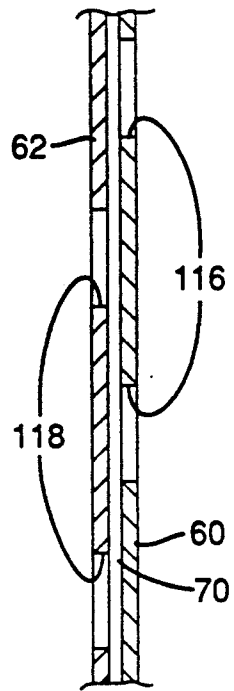

FIG. 7

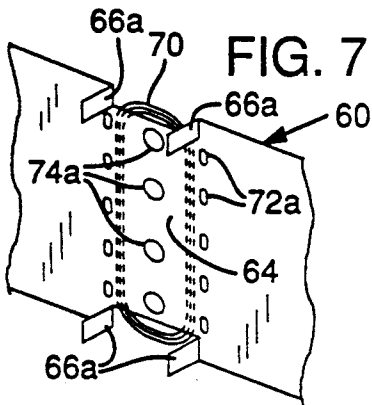

FIG. 12

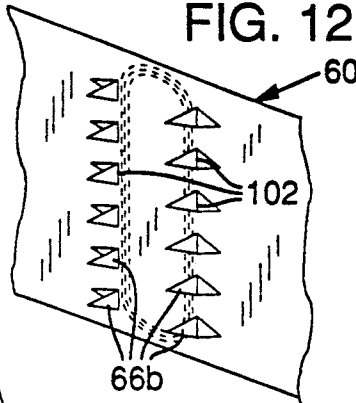

FIG. 13

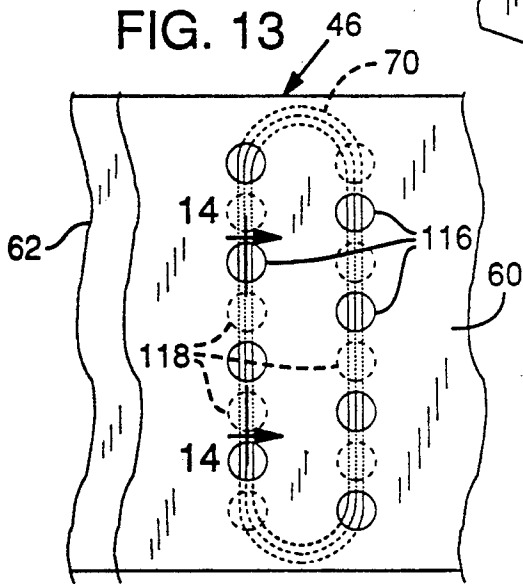

FIG. 15

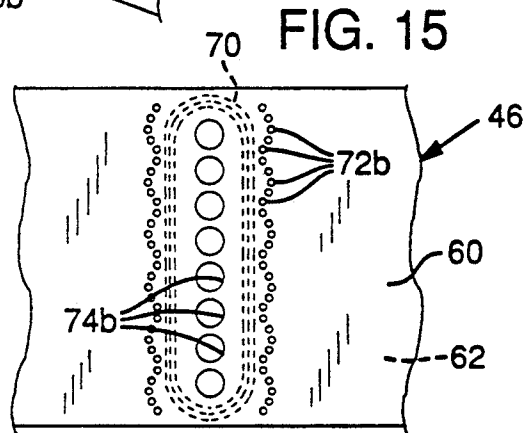

FIG. 16

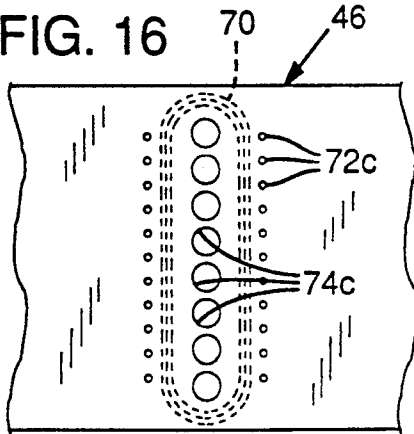

FIG. 17

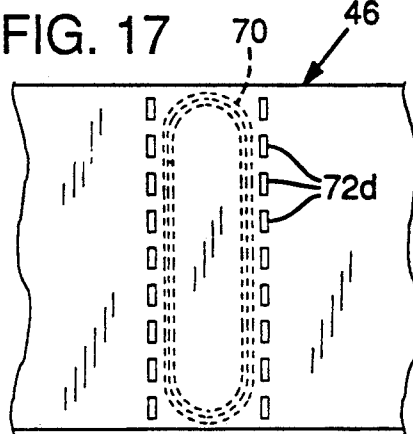

FIG. 8

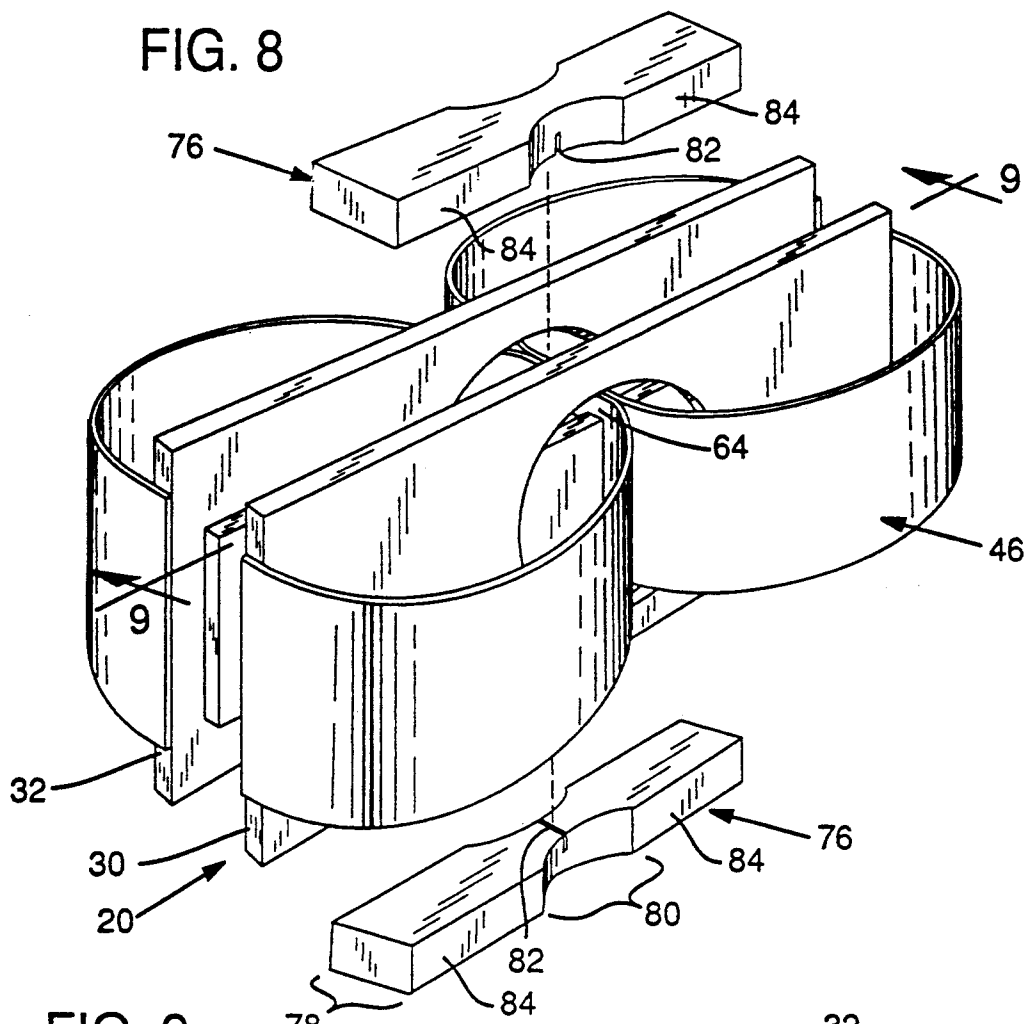

FIG. 9

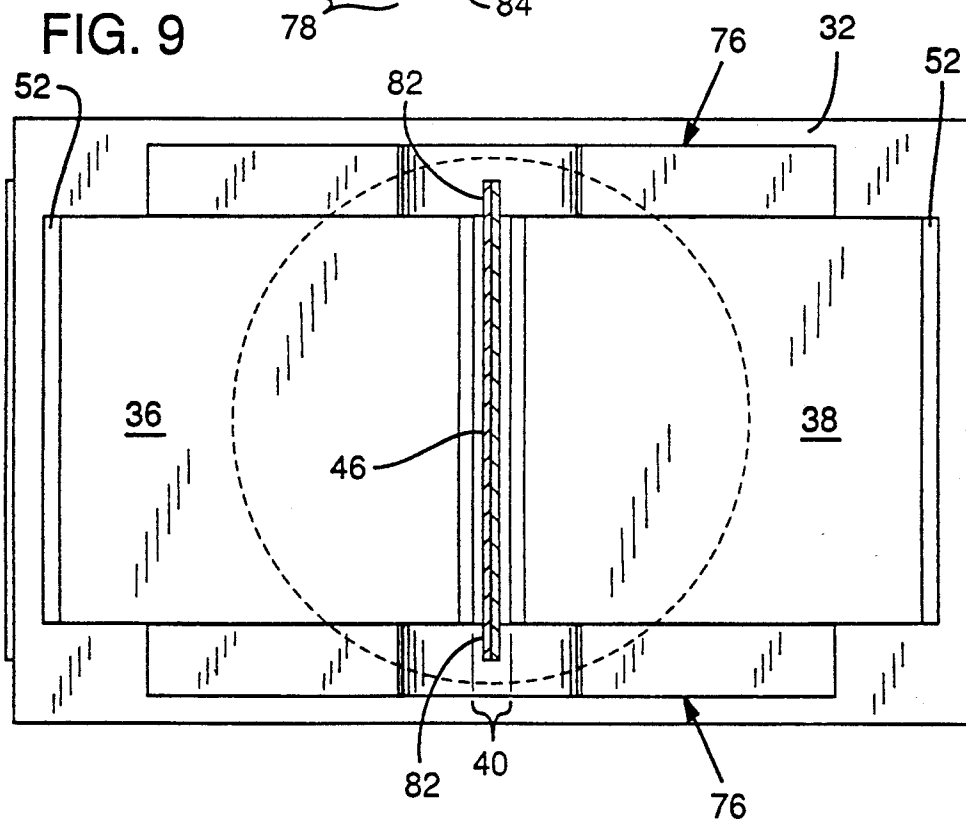

FIG. 10

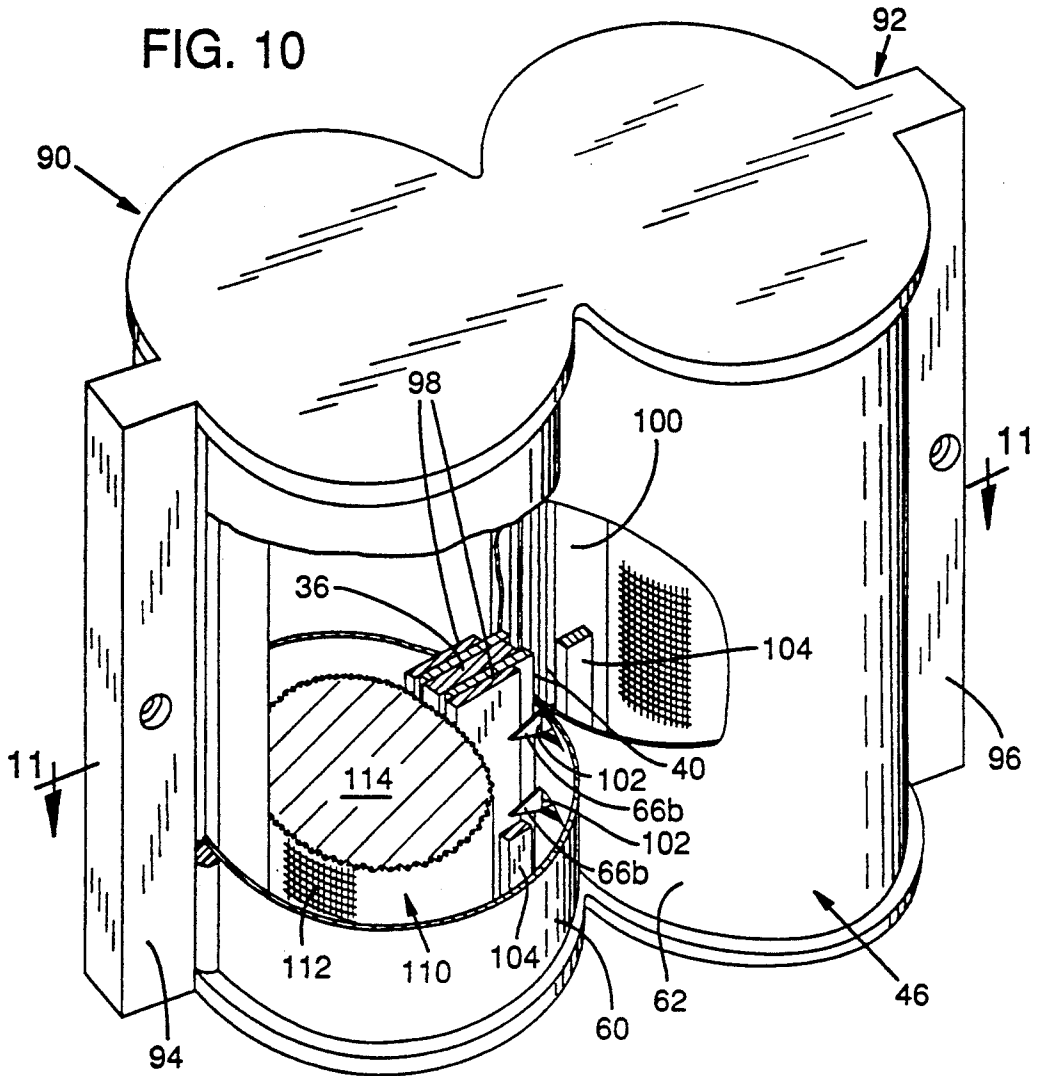
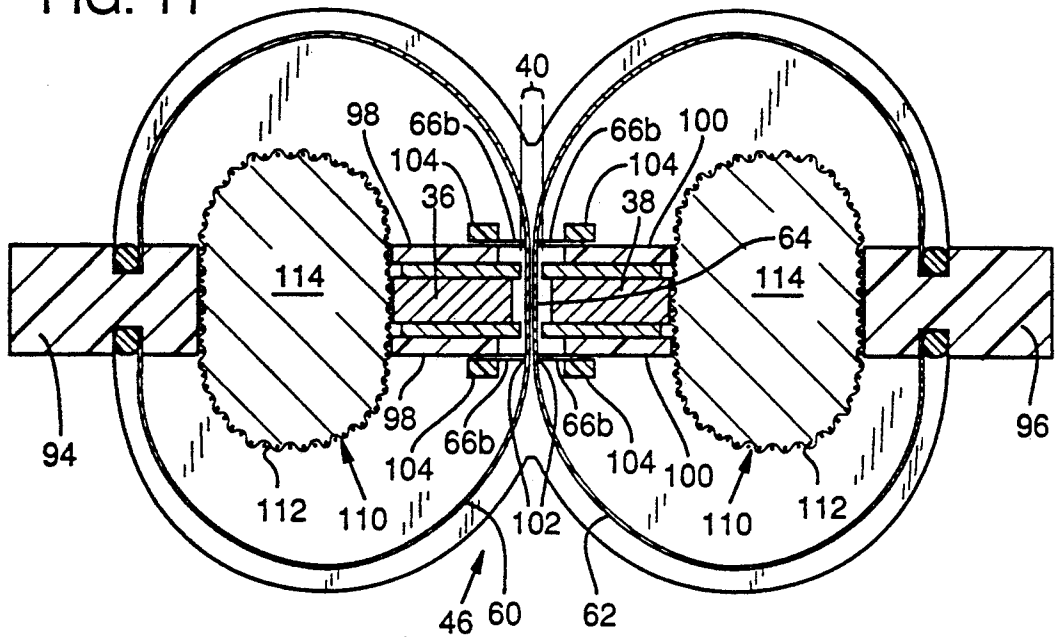
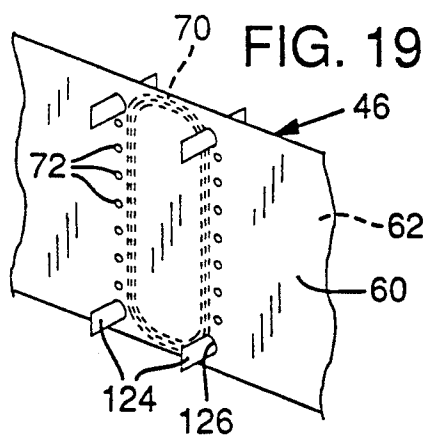
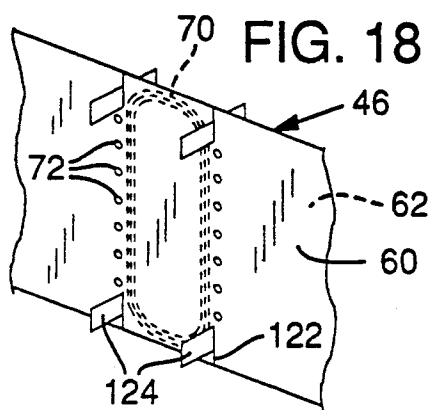

FIG. 11





AUDIO TRANSDUCER IMPROVEMENTS

Technical Field

This invention generally relates to audio transducers. More particularly, the invention relates to improvements in the design of a transducer with at least one arcuate diaphragm.

BACKGROUND OF THE ART

U.S. Pat. No. 4,903,308, which is incorporated herein by reference, discloses an audio transducer used for producing mid-range to high range frequencies. This transducer has a pair of elongated resilient webs whose intermediate portions are joined together forming an expanse that extends generally in a plane, with the expanse supported for movement in the direction of the plane. This transducer is particularly well suited for high end consumer audio markets in which cost is not a substantial concern. Therefore, the complexity of the assembly and the precise manufacturing processes required do not prevent this transducer from being highly effective and marketable. In addition, overall efficiency of the existing transducer need not be maximized due to the generally adequate power capabilities of typical home audio amplifiers.

The foregoing transducer design is not as well suited for applications in which the manufacturing cost is critical and power is limited, as in portable stereo and car stereo applications. This is true of many other prior transducer designs as well. It is always desirable to reduce manufacturing cost and to increase efficiency for any application, particularly without sacrificing performance. Also, any transducer may be improved by widening its frequency range, especially by improving its high frequency efficiency.

A fundamental problem in extending the range of frequencies in any transducer is the seemingly unavoidable trade-off between the high and low frequency performance of the transducer. Measures to improve high frequency response, such as the use of lighter diaphragm materials, have the effect of diminishing output efficiency at the lower range of the transducer. Measures to improve low frequency response, such as the use of stiffer diaphragm materials, cause high frequency losses.

All prior art devices can benefit by reducing manufacturing costs. High performance transducers generally have numerous complex parts which must be carefully aligned in a labor- and skill-intensive manufacturing process that requires many assembly steps.

A further disadvantage of many prior transducers is that the speaker coil does not easily dissipate the heat that is generated when the transducer is driven under high load conditions. The coil is typically covered by material that thermally insulates the coil.

A further drawback in many prior transducers is the less than optimum high frequency efficiency due to the moving mass of the rigid portion of the diaphragm.

A further disadvantage in the prior art is the efficiency limitation caused by the lack of precision of alignment of the diaphragm relative to the magnet structure. To provide maximum efficiency, the magnets should be closely spaced adjacent the coil. This is especially critical with small, high frequency drivers, which typically use fewer coil turns and, thus, require a high strength magnetic field. The limitation of the prior art, however, is that imprecise positioning of the diaphragm

and coil relative to the magnet creates a risk of the diaphragm contacting the magnet structure as the diaphragm vibrates or as misalignment occurs over time and use. Thus, a wide gap is required to tolerate imprecise alignment of the diaphragm and to prevent the unacceptably distorted output that occurs when the diaphragm contacts the magnet.

In the above the above-referenced prior art transducer, the diaphragms are aligned centrally in the magnet gap by a set of elastic cords, each spanning from one magnet to the other and passing through a small hole defined in the diaphragm. Although the elastic cords are sized to tightly fit the holes defined in the diaphragm, the diaphragm may slightly shift over time. This shift is tolerated by using a wider magnet gap, which results in a lower efficiency transducer unsuitable for applications such as automotive and portable stereos. An additional characteristic of this suspension approach is that the added mass of the elastic cords tends to slightly diminish the high frequency performance of the transducer.

A further characteristic of the prior art transducer making it less than ideal for portable applications, is the further reduced efficiency caused by the larger magnet pole plates, which must extend beyond the magnets to provide a rigid position for the magnets to be secured to each other across the magnet gap above and below the diaphragm, and without interfering with the diaphragm. The securing bars used for this purpose tend to limit the width of the diaphragm, resulting in limited efficiency.

A further disadvantage of all prior art audio transducers is that the diaphragm material has a less than desirable strength-to-weight ratio. In addition, the flexible materials such as the plastics and papers that are commonly used for such applications have a low resistance to solvents and acids and are highly susceptible to degradation in various types of radiation, particularly ultraviolet light as is found in outdoor applications, such as automotive installations.

A further disadvantage of the diaphragm materials used in the prior art is that the plastics and plastic coated papers commonly used have a surface that is generally incompatible with many adhesives, making manufacturing difficult by limiting adhesive choices to those adhesives with other undesirable properties.

SUMMARY OF INVENTION

An object of this invention, therefore, is to provide an improved transducer featuring a construction which overcomes the difficulties and shortcomings indicated.

More specifically, an object of the invention is to provide a transducer with an improved high frequency response without a loss of efficiency or performance at the low end of the transducer frequency range.

Another object of the invention is to provide a high performance transducer that may be inexpensively manufactured, having a small number of parts and requiring few complex manufacturing processes.

Still another object of the invention is provide a transducer wherein the speaker coil may easily dissipate accumulated heat.

A further object of the invention is to provide a transducer having a rigid moving mass of reduced weight.

Yet another object of the invention is provide a transducer wherein the diaphragm may be easily and precisely aligned within the magnet gap to safely permit a

narrowed magnet gap such that the alignment remains fixed over use and time.

It is a further object of the invention to provide a transducer with a diaphragm alignment system that does not add appreciable mass to the transducer and which is sufficiently lightweight to avoid camping the vibration of the diaphragm.

It is a further object of the invention to provide a transducer having a rigid magnet alignment structure that does not limit the width of the diaphragm employed.

A further object of the invention is provide a transducer with a diaphragm constructed from a material that has a high strength-to-weight ratio, is resistant to solvents and acids, which resists degradation on exposure to ultraviolet radiation, which has a surface that is compatible with a wide variety of standard adhesives, and which is highly thermally transmissive without warpage at high temperatures and temperature differentials.

These and other objects and advantages of the invention will become more fully apparent as the description which follows is read in conjunction with the accompanying drawings.

BRIEF DESCRIPTION OF THE DRAWINGS

FIG. 1 is a perspective view of a transducer according to the present invention used in one application as a high frequency transducer attached to a standard low-frequency speaker with a cone driver.

FIG. 2 is a perspective view of the transducer of FIG. 1 as mounted to an automobile low frequency cone driver.

FIG. 3 is a perspective view of the transducer of FIG. 1.

FIG. 4 is a cross-sectional view taken along line 4—4 of FIG. 3.

FIG. 5 is an enlarged cross-sectional view taken along line 4—4 of FIG. 3 showing the structure in the vicinity of the electrical coil.

FIG. 6 is a fragmentary perspective view of an alternate diaphragm embodiment of the apparatus of FIG. 3 in preassembled form with triangular tangs extended.

FIG. 7 shows a fragmentary perspective view of an alternate diaphragm embodiment in preassembled form with rectangular tangs extended.

FIG. 8 is a partially exploded perspective view of the transducer of FIG. 3 with an alternative diaphragm centering arrangement.

FIG. 9 is a cross-sectional view taken along line 9—9 of FIG. 8.

FIG. 10 is a fragmentary perspective view of a mid- and high-frequency transducer constructed in accordance with another embodiment of the invention.

FIG. 11 is a cross-sectional view taken along line 11—11 of FIG. 10.

FIG. 12 is a fragmentary perspective view of an alternate diaphragm embodiment of the apparatus of FIG. 10 in preassembled form with alignment tangs extended.

FIG. 13 is fragmentary side view of an alternative diaphragm embodiment of the apparatus of FIG. 10.

FIG. 14 is an enlarged cross-sectional view of the diaphragm of FIG. 13 taken along line 14—14 of FIG. 13.

FIG. 15 is a fragmentary side view of an alternate diaphragm embodiment of the apparatus of FIG. 10.

FIG. 16 is a fragmentary side view of a further alternate diaphragm embodiment of the apparatus of FIG. 10.

FIG. 17 is a fragmentary side view of a further alternate diaphragm embodiment of the apparatus of FIG. 10.

FIG. 18 is a fragmentary perspective view of an alternative diaphragm alignment arrangement of the apparatus of FIG. 3.

FIG. 19 is a fragmentary perspective view of a further alternative diaphragm alignment arrangement of the apparatus of FIG. 3.

DETAILED DESCRIPTION OF THE INVENTION

FIG. 1 shows a book shelf speaker 10 embodying the present invention in the application. The speaker includes a standard box-type enclosure 12 with a cone driver 14 for producing low- and mid-range frequencies. A high frequency transducer 20 in accordance with the present invention is mounted to the top of the enclosure 12. The driver 14 and high frequency transducer 20 are electrically connected to a standard cross-over network (not shown) so that the high frequency transducer 20 receives frequencies over 2,000 Hz and the driver 14 receives frequencies below 2,000 Hz. This cross-over point may be varied to suit the needs of the particular application. An acoustically transparent grille 21 (shown in dashed lines) may be provided to protect the speaker from dust and damage, and to provide an aesthetic appearance.

As a second exemplary application of the present invention, FIG. 2 shows an automotive speaker 22 for mounting in a typical rear deck position of an automobile interior. A standard upward facing cone-type low- or mid-range driver 24, such as a typical 6"×9" woofer, is oriented horizontally with its diaphragm facing upward. The high frequency transducer 20 is rigidly suspended above the diaphragm of the driver 24 by horizontal brackets 26 that allow substantial open space for the sound emitted by the driver 24 to be upwardly projected. The high frequency transducer 20 thereby protrudes above the rear deck (not shown) and transmits sound directly forward toward the automobile passengers. The high frequency transducer 20 and driver 24 are interconnected by a cross-over network (not shown) as discussed above with reference to speaker 10 of FIG. 1. A protective grille (not shown) may be used to shroud the speaker 22.

As shown in FIG. 3, the high frequency transducer 20 is generally of a rigid, layered construction. This construction includes a chassis or frame having a front chassis plate 30 and a rear chassis plate 32. Plates 30, 32 are vertically oriented rectangular plates made preferably of a rigid plastic material. The plates are identical to one another and oriented in a parallel, laterally spaced relationship. Each plate defines a circular central aperture 34 having a diameter that is a substantial fraction of the height of the chassis plates 30, 32, to permit passage of large items without sacrificing rigidity. The apertures of the plates are in registration with one another. A first magnet assembly 36 and a second magnet assembly 38 are supportively sandwiched between the chassis plates 30, 32 with the chassis plates adhesively affixed thereto to provide a rigid chassis structure. The magnet assemblies 36, 38 thereby provide a fixed magnetic field suitable for interaction with a coil carrying an electrical current as will be discussed below. The magnet assem-

blies 36, 38 are rigid rectangular structures arranged symmetrically and orthogonally between the chassis plates 30, 32 to define a magnet gap 40 of constant width therebetween. The magnet gap 40 extends vertically the full height of the magnet assemblies and if extended laterally, would bisect the central apertures 34. Thus, the centers of the apertures are aligned with the magnet gap.

To maximize speaker efficiency, the magnet gap should be as narrow as possible while allowing sufficient clearance to permit passage of a planar diaphragm 46 as will be discussed below. The ideal gap width varies depending on the size of the transducer and application being fulfilled. The magnet gap 40 may range between 0.020 and 0.062 inch, with a spacing of inch being preferred in the particular high frequency transducer 20 illustrated.

As shown in FIG. 4, each magnet assembly 36, 38 comprises a magnetic core 48, 50, respectively, with a pair of rigid, ferro-magnetic metal pole plates 52 affixed to the opposite sides of each magnetic core. The pole plates 52 are generally coextensive with the magnetic cores 48, 50, extending slightly beyond the magnetic cores in the direction of the magnet gap 40 so that the separation between opposed pole plates 52 defines the magnet gap. The magnetic cores 52 are magnetically oriented so that each pole plate is of opposite magnetic polarity from the other pole plate attached to the same magnetic core and so that each pole plate 52 is also magnetically opposite from its counterpart across the magnet gap 40.

It will be apparent from the foregoing that each chassis plate is adhered to one of the pole plates of each magnet assembly to provide a sandwich construction which is perfectly symmetrical.

The diaphragm 46 is formed of a pair of elongate resilient webs 60, 62. The paired structure provides a symmetrical structure, but a single diaphragm may be used where this characteristic is unnecessary. Each web includes flexible curved portions forming the end of each web, joined to and extending from an intermediate, generally planar central portion 64 also indicated in FIG. 5. Web 60 includes a front curved portion 60a, a rear curved portion 60b and a central expanse 60c. Web 62 includes a front curved portion 62a, a rear curved portion 62b and a central expanse 62c. The central expanses 60c, 62c of the two webs are joined together, as with an adhesive, to form the central portion 64. The central portion 64 is an essentially rigid unit functioning as a narrow beam, and is movable generally in the plane occupied by the expanse. That is, it moves perpendicularly to the plane of the chassis plates 30, 32. Thus, the central portion is movable laterally relative to the transducer as a whole.

The diaphragm 46 is preferably constructed of an aramid fiber paper sheet such as Nomex®, produced by DuPont, but other flexible, lightweight, high-strength, environmentally stable materials may be used.

The central portion 64 of the diaphragm 46 is suspended centrally within the magnet gap 40 by the flexible curved portions 60a, 60b, 62a, 62b. The end of each flexible curved portion is attached adhesively to a respective end portion 30a, 30b, 32a, 32b of each chassis plate 30, 32 so that each flexible portion forms a semi-circular shape, giving the diaphragm the general shape of a figure-eight when viewed from above or below. The curved portions of each web define curved surfaces which extend through respective central apertures 34

to meet at the expanse. The curved portions 60a, 60b, 62a, 62b primarily act as flexible suspension members and not as sound radiating surfaces. This is particularly true at high frequencies, at which only the portions of the diaphragm 46 closest to the center portion 64 are actively radiating sound. Thus, alternate suspension devices may be used without impairing the function of the invention, particularly at high frequencies.

FIG. 5 shows the central portion 64 of the diaphragm 46 that resides within the magnetic gap 40. As will be discussed below with reference to FIG. 6, a set of tab portions or tangs 66 are partially cut from the diaphragm 46 and folded perpendicular to the central portion 64 of the diaphragm so that they extend in planes substantially coincident with the exterior surfaces of the pole plates 52, to which the free ends of the tangs 66 are adhesively attached. The central apertures 34 are large enough to expose a sufficiently large area of the exterior surfaces of the pole plates 52 to permit the tangs to be attached thereto. As a result, the central portion 64 is maintained in the central location between the magnets while being free to move laterally within its own plane by a sufficient amount to produce high audio frequencies. The tangs 66 prevent longitudinal movement of the central portion 64 of the diaphragm 46, while permitting unimpaired lateral movement in the plane of the central portion 64.

FIG. 5 further illustrates an electromagnetic coil 70 laminated between the central expanses 60c, 62c of the web 60, 62 to become a rigid portion of the central portion 64. The vertical portions (shown in cross-section) of the coil 70 are positioned in the regions immediately between the pairs of opposed pole plates 52.

FIG. 6 shows web 60 in a straightened, partially preassembled condition with triangular tangs 66 cut and folded in position for attachment to the magnet pole pieces 52. In this embodiment, one edge of each tang is an extension of either the upper or lower portion of the web, depending on whether the tang is the upper or lower tang. The coil 70 (shown in dashed lines) is an elongate looped coil of wire forming a vertically oriented generally oblong or rectangular shape, with a pair of opposed straight, vertically oriented wire segment portions being spaced apart to align with the magnet pole pieces 52. Similar tangs are cut in web 62 (not shown) and folded in the opposite direction as those shown, providing a symmetrical diaphragm.

As further shown in FIG. 6, the diaphragm 46 is provided with a vertical row of hinge perforations 72 on each side of the coil 70. The perforations are preferably aligned with the folded tangs 66 and are positioned within about $\frac{1}{4}$ inch of the coil 70 and hence within about $\frac{1}{4}$ inch of the joined expanse portion. The tangs are integral extensions of the web formed by folding pre-slitted tab-like portions of the web. Positioning the perforations 72 close to the coil 70 effectively reduces the mass of the rigid center portion 64 of the diaphragm 46. The perforations 72 may be circular as shown or, alternatively, may be any other shape including oblong, square or elliptical and may alternatively be sheared line segments with no diaphragm material removed. FIG. 6 further shows the center portion 64 defining mass reduction holes 74, the advantages of which are discussed below with reference to FIG. 7.

Each row of perforations acts like a hinge to permit a less constrained, more responsive movement of the central diaphragm expanse portion 64. The size of the perforations is not critical, only the proportion of mate-

rial removed affects the key property of hinge-like flexibility at the edges of the center portion 64. Along the hinge center line of each row of hinge perforations 72, the sum of the linear dimensions of the perforations is preferably between about 10% and 50% of the full linear dimension of the web 60 along the same vertical line. With current materials used, the perforations define a pair of hinge lines at which the web material is preferably about 80% connected and 20% perforated. Thus, it is apparent that the web shown in FIG. 6 is less than 20% perforated and thus less than optimum. The foregoing parameters likely will become better defined with further experimentation.

The added hinge-like flexibility provided by the perforations 72, permits the efficiency of the transducer at very high frequencies to be substantially increased as the rigid central portion 64 of the diaphragm 46 is able to move more independently of the mass of the web curved portions 60a, 60b, 62a, 62b. In addition, the reduced mass resulting from the removal of the diaphragm material is the close vicinity of the central portion may also contribute to this effect. Experimental analysis has shown a 3 to 6 db increase in output over the 12 to 24 kHz high frequency range, with no sacrifice in efficiency at the low end of the transducer's output. Previous attempts to provide an improved high frequency efficiency, such as using a lighter and more flexible diaphragm material, have resulted in an undesirable drop off in low frequency performance.

FIG. 7 shows a web 60 having an alternative arrangement of tangs 66a and perforations 72a. In this embodiment, the tangs are rectangular and folded perpendicularly outward from their original pre-folded positions in the center portion 64 of the diaphragm 46 covering the end portions of the coil 70. While it is generally desirable that the coil be supported by and rigidly affixed to the webs 60 and 62, this is only important along the vertical portions of the coil (shown in dashed lines), which magnetically interact with the magnets shown in FIGS. 3 and 4. The exposed end portions of the coil 70 need not be supported. A further advantage of the FIG. 7 web construction is that the exposed end portions of coil 70 dissipate accumulated heat more effectively, as they are directly exposed to the environment.

The perforations 72 are shown in FIG. 7 as oblongs aligned axially in a vertical row, but any shape may be used as discussed above with reference to FIG. 6. As in FIG. 6, FIG. 7 shows only a single web 60. A similar web 62 would be adhered at the central portion 64 to create a sandwich, with the coil 70 between the webs. FIG. 7 also shows central mass reduction perforations 74 defined in the central portion 64 of the diaphragm, and centered entirely within the coil 70 to reduce the mass of the central portion 64. The central portion 64 is rigid and functions essentially as a planar beam translating in its own plane. The mass reduction provided decreases the inertia of the central portion 64 and results in a slight improvement in high frequency efficiency, with a subjectively perceptible increase in the quality of sound perceived as quickness.

FIGS. 8 and 9 show the high frequency transducer 20 with an alternative diaphragm centering mechanism. Instead of the tangs 66 formed of the diaphragm 46 to align the diaphragm within the magnet gap 40, as shown in FIGS. 3-7, the embodiment of FIG. 8 uses a pair of elongated foam members 76 to retain the central portion 64 of the diaphragm centrally within the magnet gap 40. Each foam member has a width 78 sized to closely fit

between the front and rear chassis plates 30, 32. Each foam member 76 has a slitted central neck portion 80 with a reduced width. A slit 82 is cut across the width of the neck portion to a depth of about one-half the thickness of the foam member. The foam members 76 are attached to the high frequency transducer 20 by mating the slits 82 with the corresponding top and bottom edges of the central portion 64 of the diaphragm 46 and adhesively securing the sides 84 of the foam member 76 to the inner surfaces of the chassis plates so that the foam members rest against the magnets 36, 38 and are entirely positioned between the chassis plates 30, 32. In addition, the slits 82 are adhesively secured to corresponding edges of center portion 64 of the diaphragm 46.

The diaphragm 46 is thereby retained perfectly centered within the magnet gap 40 by the slits 82 provided in the elongated foam members 76. Because the foam members 76 are formed of a lightweight open cell foam having a low resistance to small displacements, they have a negligible damping effect on high frequency vibrations of the diaphragm 46, yet they preserve a central alignment of the diaphragm 46 that is not susceptible to shifting over time.

FIGS. 10 and 11 show a wide range, mid- to high-frequency transducer 90 embodying the invention as an essentially improved version of the audio transducer disclosed in U.S. Pat. No. 4,903,308. Transducer 90 operates on the same general principle as the high frequency transducer 20, with a diaphragm 46 formed by webs 60, 62, as a figure-eight shape. The central portion 64 of the diaphragm 46 passes through the magnet gap 40 (FIG. 11) with a coil 70 (not shown) sandwiched between the webs 60, 62 and residing within the magnet gap in the manner precisely described. In this larger embodiment of the transducer 90, a larger chassis 92 retains the diaphragm 46 and the magnet assemblies 36, 38. The chassis 92 is formed generally of spaced apart vertical diaphragm retaining members 94, 96 and two opposed pairs of central opposed vertical magnet retaining members 98, 100 located between the diaphragm retaining members 94, 96. The magnet retaining members 98 comprise a pair of rigid vertical planar members spaced apart sufficiently so that magnet assembly 36 may be rigidly affixed therebetween to define the magnet gap 40 with the opposite magnet assembly 38, which is similarly affixed between the opposing pair of magnet retaining members 100.

FIGS. 10 and 11 further show a diaphragm centering means including triangular alignment tangs 66b formed by V-shaped cuts in each web 60, 62. The apex of each "V" forms a free end that points horizontally away from the central portion 64 of the diaphragm 46. The base of each "V," that is, the portion closest to the central portion 64 of the diaphragm 46 and integrally attached to the diaphragm at a fold line 102, extends substantially perpendicularly from the web in a plane parallel to the exposed exterior surface of the adjacent magnet retaining pair member 98, 100 so that the tang 66b may be adhered to or secured against the adjacent retaining member. With the diaphragm 46 suitably centered in the magnet gap 40, the free end tips of the tangs are adhered or clamped to the exposed surfaces of the magnet retaining pair members 98, 100 and covered by rigid elongated tang retaining members 104, which are adhesively affixed to the magnet retaining pair members 98, 100 so that the tips of the tang 66 are sandwiched therebetween. The cuts forming the tangs 66 have the

additional advantage of providing a flexible hinge line as discussed above with respect to the hinge perforations 72 and 72a of FIGS. 6 and 7. Additional perforations (not shown) between tangs 66b may be provided to increase the diaphragm's flexibility still further.

FIGS. 10 and 11 also show a pair of cylindrical acoustic dampers 110 oriented vertically and positioned between the respective diaphragm retaining member 94, 96 and magnet retaining pair 98, 100 in each chamber defined by the respective circular web 60, 62. Each damper 110 is formed by a cylindrical tube of perforated webbing, such as a flexible plastic mesh 112, which is filled with a core of lightweight fibrous stuffing 114. The stuffing 114 may be any suitable material, such as wool, felt, cellulose fiber or fiberglass. The dampers prevent internal acoustic reflections and vibrations from degrading the output sound.

FIG. 12 shows preassembled web 60 of the embodiment of FIGS. 10 and 11 with the tangs 66b shown as "V" cuts and folded along fold lines 102. Tangs 66 are arranged in two vertically aligned rows, one row on each side and located about $\frac{1}{4}$ inch from coil 70. Like tangs 66, tangs 66b are formed as integral folded extensions of the diaphragm.

FIGS. 13 and 14 show an alternative configuration of the diaphragm 46 for use on the mid- to high-frequency range transducer 90 of FIGS. 10 and 11. Web 60 is provided with a plurality of circular holes 116 arranged in vertical rows registered with the linear vertical portions of the coil 70. The holes 116 are spaced apart in each row by a center-to-center distance greater than twice the diameter of the holes. The holes are staggered in each row so that the holes in one row are aligned with the mid points between centers of adjacent holes in the opposite row. The web 62 is provided with an identical set of holes 118, shown in dashed lines. Webs 60, 62 are registered with the holes 116, 118 aligned in reverse registration so that each hole 116 overlies a solid unbroken portion of adjacent web 62 and each hole 118 underlies a solid, unbroken portion of adjacent web 60. Therefore, there are no openings passing entirely through both webs 60, 62. The coil 70 is adhesively laminated between the webs 60, 62 so that its vertical linear sections are generally aligned with the rows of holes 116, 118. Because of the arrangement of holes 116, 118, every point along the entire length of the coil 70 is adhered either to web 60 or web 62 or both. This prevents any undesirable relative motion between the coil 70 and the webs 60, 62. Because the webs 60, 62 are adhered only to the coil, and not to each other in the region beyond the periphery of the coil, the holes 116, 118 provide the hinge-like flexibility discussed above, and produce high frequency efficiency improvements without sacrificing low frequency efficiency. In addition, heat in the coil 70 is readily dissipated by the substantial portions exposed to air through the holes 116, 118, while performance is maintained with a rigidly attached coil.

FIG. 15 shows an alternative diaphragm arrangement for the transducer 90 of FIGS. 10 and 11. An articulated row of perforations 72b is defined entirely through the diaphragm 46, penetrating both webs 60, 62 on both sides of the coil 70. The perforations as shown are circular, but numerous other shapes are contemplated and may be substituted. The holes 72b of this embodiment are separated by at least a minimal distance from the coil 70 to ensure that the coil is entirely adhered to the diaphragm 46. At least a portion of some of the perfora-

tions preferably are within at least about $\frac{1}{4}$ inch of the coil 70 to provide optimal flexibility in the diaphragm 46 for high frequency efficiency. FIG. 15 further shows a centrally aligned row of mass reduction perforations 74b positioned in a vertical row within the coil 70. The perforations 74b may pass entirely through the diaphragm 46 or may each be defined only in a single web 60 or 62 so that through holes are not provided through the diaphragm. In an alternative embodiment, a thin film or sheet of thin material may be provided between the webs 60, 62 to close the perforations 74b while allowing the advantages of substantial weight reduction.

FIG. 16 shows an additional alternative embodiment, with diaphragm 46 having hinge perforations 72c defined in the diaphragm 46 as small diameter circular holes in a linear configuration. In this embodiment shown, about 20% of each row is perforated while about 80% of the diaphragm remains connected at each row. FIG. 16 further shows the optional mass reduction perforations 74c.

FIG. 17 shows a further alternative diaphragm 46 embodiment having elongated rectangular perforations 72d that provide a hinge-line of approximately 50% perforated length and 50% connected length.

It will be appreciated that the perforations 72 located along the outside vertical edges of coil 70 can have a wide variety of shapes and sizes. The perforations 72, for example, have a diameter of about $\frac{3}{32}$ inch and are spaced apart about $\frac{1}{4}$ inch. Perforations 72a have a length of about $\frac{1}{8}$ inch and are spaced apart about $\frac{1}{4}$ inch. Similarly, perforations 72b have a diameter of about $\frac{1}{8}$ inch and a spacing of about $\frac{1}{4}$, and perforations 72c have a diameter of about $\frac{3}{16}$ inch and a spacing of about $\frac{1}{2}$ inch.

The increased flexibility and compliance which the perforations 72 provide the diaphragm is, in part, a function of the distance of the perforations from the vertical edge of the coil (which edge also defines the edge of the rigid central portion formed by adhering the two webs together). The perforations preferably eliminate diaphragm material along a hinge line within about $\frac{1}{2}$ inch and, most preferably, within $\frac{1}{4}$ inch or less of the vertical edges of the central joined-together portion of the webs. As this distance increases, spacing the perforations further from the coil, the increased flexibility and compliance drops off because the perforations are located farther from "hinge zone" on either side of the rigid beam-like central portion and hence farther from the primary high frequency radiator zone.

As the perforations move toward the coil to the point where they overlap the coil and extend into the rigid central portion area, the perforations cease to contribute increased flexibility but still improve the diaphragm performance to some extent by reducing the mass of the central portion which oscillates in response to the changing magnetic field.

For balance, it is important that the perforation pattern on both sides of a vertical line bisecting the coil be substantially symmetric. When web 60 in FIG. 13 is considered by itself, the perforations 116 do not provide a perfectly symmetric pattern as just noted. However, the webs 60 and 62 together do provide a balanced symmetry as FIG. 13 illustrates. It is also desirable that the perforation patterns above and below a horizontal line bisecting the coil also be symmetric.

FIG. 18 shows an alternative approach for suspending and aligning the diaphragm 46 in the magnet gap 40.

The diaphragm defines a pair of vertical slits 122 at both the upper and lower edges thereof, with the slits being aligned to register with the magnet pole plate surfaces 52 when the diaphragm is installed. An elongated rectangular tab 124 is inserted into each slit 122 so that it extends perpendicularly by an equal amount from each side of the diaphragm. Each tab is preferably formed of a strong and flexible sheet of material similar to the diaphragm. The free ends of each tab 124 are adhered to the magnet pole plates. The tabs have sufficient thickness that the diaphragm slits 122 do not shift or slide along the tabs during normal use. A deliberate force may be used to adjust the alignment during assembly.

FIG. 19 shows an alternative alignment approach using similar tabs 124 as in the embodiment of FIG. 18. Instead of retaining the tabs 124 in slits 122, however, the diaphragm defines tab holes 126 corresponding with the slit 122 positions of FIG. 18. The tab holes 126 are sized slightly smaller than the width of the tabs 124 so that the tabs resist sliding through the holes 126. The tabs 124 may thus need to be curved to pass through the holes when inserted during assembly. The tab holes 126 are shown as circular, but any shape, such as an ellipse or diamond, that snugly retains the tab 124 in a vertical plane is suitable.

It will be appreciated that while the use of alignment tangs, central mass reduction perforations, and hinge flexibility perforations is preferred, the principles of the present invention can be applied with fewer than all of the above features, or with only one of the selected features.

Having illustrated and described the principles of my invention by what is presently a preferred embodiment, it should be apparent to those persons skilled in the art that the illustrated embodiment may be modified without departing from such principles. I claim as my invention not only the illustrated embodiment, but all such modifications, variations and equivalents thereof, as within the true spirit and scope of the following claims.

I claim:

1. An audio transducer comprising:

first and second magnet assemblies, each having opposed side surfaces;

support means affixed to the side surfaces of the first and second magnet assemblies for supporting the magnet assemblies in a rigid aligned relationship with a gap therebetween, the support means defining a pair of opposed diaphragm openings aligned with the gap;

a diaphragm assembly comprising a pair of flexible first and second webs having central portions joined together to form a movable expanse, each web having opposite end portions which are supportively affixed to the support means, a portion of the diaphragm being received within the diaphragm openings;

the support means supporting the diaphragm such that the movable expanse is located centrally within the gap; and

coil means attached to the expanse of the diaphragm.

2. The transducer of claim 1 further including connecting means for conducting electrical impulses to the coil means.

3. The transducer of claim 1 wherein the support means includes a pair of parallel, laterally spaced support plates, each of which defines one of the diaphragm openings.

4. The transducer of claim 3 wherein each support plate has a pair of opposed end surfaces to which one of the end portions of one web is affixed such that the webs are supported in a substantially figure eight configuration.

5. The transducer of claim 4 wherein the end portion of each web is adhered to the end surface of one of the support plates.

6. The transducer of claim 1 wherein the coil means is adhered directly to both webs.

7. The transducer of claim 1 further including centering means for centering the expanse in the gap between the first and second magnet assemblies.

8. The transducer of claim 7 wherein the centering means includes tab means integrally formed from at least one of the webs for connecting the web to one of the magnet assemblies so as to constrain the expanse from moving toward or away from the magnet assemblies while permitting the expanse to move laterally.

9. The transducer of claim 8 wherein the tab means includes plural tabs integrally formed from the first web and plural tabs integrally formed from the second web, the first web having at least one tab affixed to one of the side surfaces of the first magnet assembly and at least one tab affixed to the other side surface of the first magnet assembly, the second web having at least one tab affixed to one of the side surfaces of the second magnet assembly and at least one tab affixed to the other side surface of the second magnet assembly.

10. The transducer of claim 8 wherein the tab means includes plural tabs formed by bending slit portions of the diaphragm substantially perpendicularly along a hinge line proximate to the expanse.

11. An audio transducer comprising:

a pair of first and second magnet assemblies

first and second support plates affixed to the first and second magnet assemblies, the support plates supporting the magnet assemblies such that the magnet assemblies are disposed between the support plates and in an aligned spaced apart relationship to one another to define a magnet gap therebetween, each support plate defining a central diaphragm opening aligned in registration with the magnet gap;

a diaphragm comprising a pair of elongate flexible webs having central portions joined together to form a movable expanse located between the first and second magnet assemblies, each web having opposite end portions, one end portion of which is affixed to the first support plate and the other end portion of which is affixed to the second support plate, the webs being supported such that they extend through both central diaphragm openings and define curved surfaces which are mere images of one another; and

coil means attached to the expanse of the diaphragm.

12. An audio transducer comprising:

a pair of first and second magnet assemblies spaced apart by a magnet gap therebetween, each magnet assembly having a magnetic core and a pair of first and second magnetic pole plates of opposite magnetic polarity affixed to opposite sides of the magnetic core;

a pair of first and second parallel plates affixed to the pole plates such that the first and second magnet assemblies are disposed therebetween, the first and second plates each defining a central opening aligned with the magnet gap;

13

a diaphragm comprising a pair of elongate curved webs having central portions joined together to form a movable expanse supported within the magnet gap, each web extending through the central openings in the first and second plates and having opposite end portions, one of which is affixed to an end of the first plate and the other of which is affixed to an end of the second plate, whereby the webs are supported such that they form a substantially figure eight pattern; and

coil means attached to the expanse.

13. The transducer of claim 12 wherein the webs are each made of NOMEX® fiber paper.

14. An audio transducer comprising:

a pair of first and second magnet assemblies;

a frame for supporting the magnet assemblies adjacent to one another with a gap therebetween;

a diaphragm comprising a pair of first and second elongate flexible webs having central portions joined together to form a movable expanse located in the gap, the webs each having opposite end portions;

web supporting means for supporting the end portions of the webs such that the webs form curved surfaces which are mirror images of one another;

centering means for centering the expanse in the gap, the centering means including tab means integrally formed from at least one of the webs; and

tab securing means for securing the tab means against at least one of the magnet assemblies.

15. The transducer of claim 14 wherein the tab means includes at least one tab projecting from the first web and at least one tab projecting from the second web, the tab securing means securing the tab projecting from the first web against the first magnet assembly and securing

14

the tab projecting from the second web against the second magnet assembly.

16. The transducer of claim 14 wherein each web has plural tabs formed from slit web portions which are bent substantially perpendicularly along a hinge line adjacent the expanse, the tabs of the first web being secured against the first magnet assembly and the tabs of the second web being secured against the second magnet assembly.

17. The transducer of claim 14 wherein the tab securing means includes glue for adhering the tab means against the magnet assemblies.

18. The transducer of claim 14 wherein the tab securing means includes at least one securing bar affixed to the magnet assembly and overlying the tab means so as to sandwich the tab means therebetween.

19. An audio transducer comprising:

a frame;
a diaphragm comprising a pair of elongate webs having portions joined to each other to form a movable substantially planar expanse, the webs each having flexible end portions extending from the expanse in an arc to a remote frame location;

coil means attached to the expanse of the diaphragm; magnetic means adjacent to and on opposite sides of the expanse for producing opposing magnetic fields extending normal to the expanse;

centering means for centering the expanse within the magnetic field, the centering means including at least one tab extending from the first web away from the expanse in one direction and at least one additional tab extending from the second web away from the expanse in the opposite direction; and

tab securing means for securing the tabs against the magnetic means.

* * * * *

40

45

50

55

60

65